

DATA SHEET



VERLICHTING

The Wick is an elegant wall-mounted sconce that effortlessly blends classic nautical charm with refined industrial aesthetics.

Crafted with a rich, lantern brass finish, this sophisticated fixture features a graceful gooseneck arm that beautifully suspends a wide, conical metal shade.

Whether illuminating an entryway, a covered patio, or a vintage-inspired interior, the Wick adds timeless architectural character and durable functionality to any setting.

Article Reference: **Wick - Lantern Brass**
Item Reference: **32194**



Pattern design only for Reference

DIMENSIONS (approx. dimensions in cm)

Ø	H	D
26,5	38,5	39,5

MATERIAL SPECIFICATION

Body:	Brass & Glass
Composition of Brass:	63% Copper & 37% Zinc
Internal wiring:	2 x 0,75 mm ²
Lamp holder:	1 x E27

Product Weight 2,400 kg

ELECTRICAL SPECIFICATION

Power supply:	220-240V / 50-60 Hz
Maximum Wattage (LED):	7 W
Cable Entry:	Single

Area



Suitable for Indoor & Outdoor Use

IP-Rating

IP-54

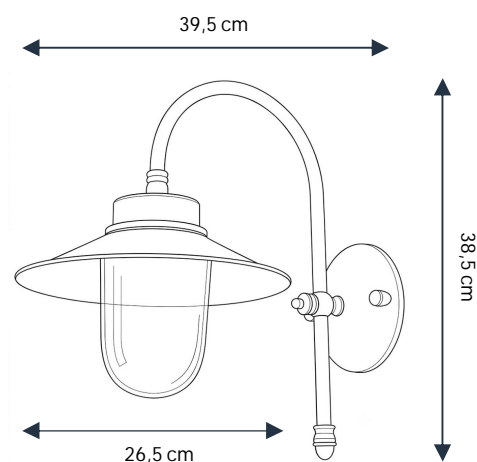

MOUNTING OPTIONS

Wall mounted - fixed.